

# TC-200



The TC200 High Resolution Counting Scale is a very user friendly design. With simplicity and ease of use in mind, operators will have a short learning curve and minimum of frustration. Scale data is communicated from triple Vacuum Fluorescent Displays to allow simultaneous viewing of Gross weight, APW, and Piece Count. The TC-200 is a mid size scale in stature but is BIG on performance. By utilizing 600,000 internal counts, a wide range of parts can be counted quickly and accurately.



TRANSCCELL TECHNOLOGY, INC.

COUNTING SCALES

# TC-200

## HIGH PERFORMANCE COUNTING SCALE

### STANDARD FEATURES & BENEFITS

**\* HIGHLY VISIBLE GREEN VFD DISPLAY:**

Scale display can easily be viewed from up to 20" away. The three displays simultaneously show Gross Weight, APW, and Piece Count.

**\* HIGHLY DURABLE:**

Easily withstands the rigors of industrial applications, utilizing an ABS case, an all steel frame, and a stainless steel platter.

**\* 22 KEY TACTILE KEYPAD:**

The 22 key membrane panel allows entry of numeric data, such as known tare values, APW's, and specific sample sizes from 1 to 999,999.

**\* RS-232 PORT:**

Provides transmission of an APW to the TC-2001, TC-2005 or TC-2010. Also provides transmission to a printer, computer, remote display or other compatible devices.

**\* 1:600,000 INTERNAL RESOLUTION:**

High internal resolution provides greater sensitivity, for increased counting accuracy and weighments.

**\* ACCUMULATOR FUNCTION:**

Can accumulate either pieces or weight, and print total.

### Specifications

**Display:** 16 Character, 7-Segment Green Vacuum Fluorescent (VFD)

**APW Transfer:** The APW can be transferred to the TC-2001, TC-2005, or TC-2010 utilizing the RS-232 port.

**Counting Capacity:** 999,999

**Weighing Resolution:** 1 part in 500 to 1:50,000 max.

**Keyboard Set-up and Calibration:** Calibration and set-up parameters all keyboard accessible, for speedy installation.

**Units of Measure:** lb / kg

**Operating Temperature:** 32° F to 104° F (0° C to 40° C)

**Power Requirements:** AC Adapter, 12 VDC, 800mA, included

**Housing:** Grey ABS

**Base and Sub Platform:** Metal

**Platform:** Stainless Steel

**Feet:** Non-Skid Hard Rubber

**Shipping Weight:** 16.0 lb (7.2 kg)

**Warranty:** 1 Year Limited Warranty

TC-200 Back Panel



#### CAPACITIES & SIZES

TC-200-6	6 lb x 0.0005	TC-200-3M	3000 g x 0.2 g
TC-200-12	12 lb x 0.001	TC-200-6M	6000 g x 0.5 g
TC-200-30	30 lb x 0.002	TC-200-15M	15 kg x 0.001 kg (1 g)
TC-200-60	60 lb x 0.005	TC-200-30M	30 kg x 0.002 kg (2 g)

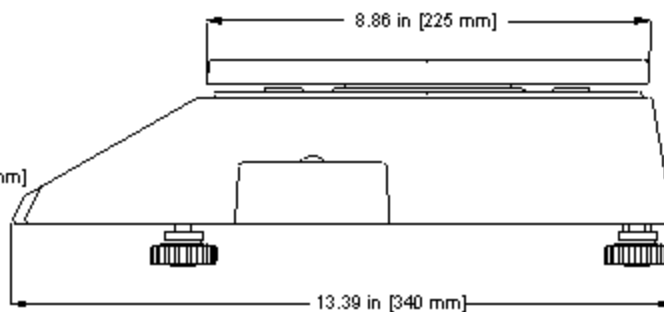
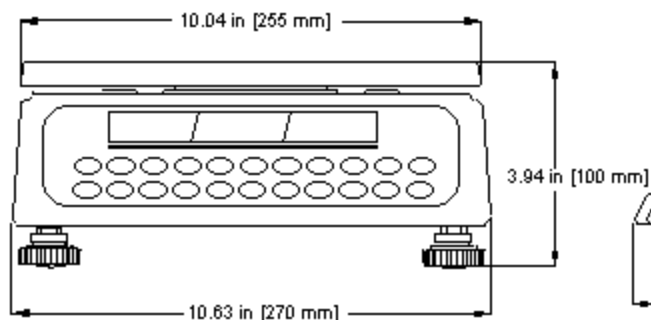

**YOUR AUTHORIZED TRANSCELL DEALER IS:**

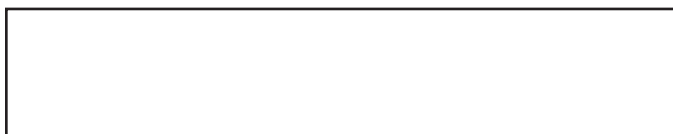

Specifications and features subject to change without notice.

REV 5-15-03



**TRANSCELL TECHNOLOGY, INC.**

975 Deerfield Pkwy, Buffalo Grove, IL 60089

Tel (847) 419-9180 Fax (847) 419-1515

**(800) 503-9180**

www.transcell.net